

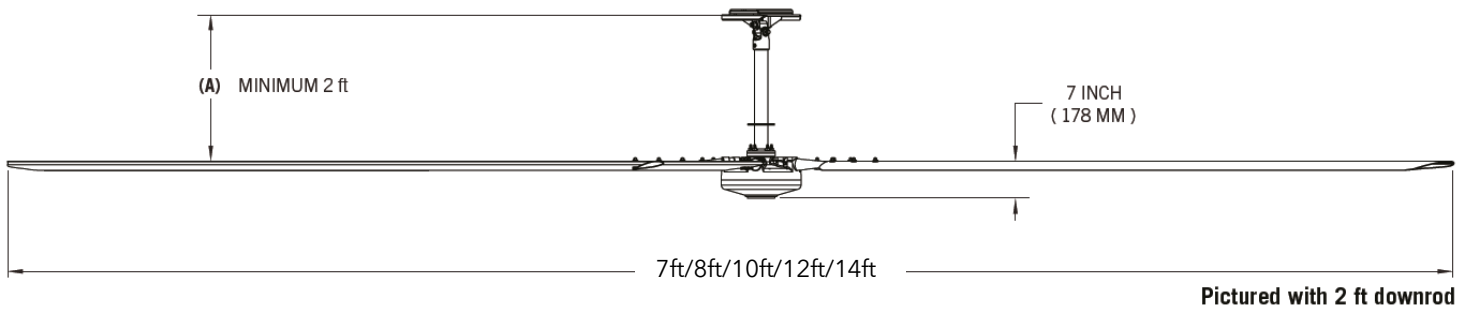

XP

AIRFOIL DIAMETER	7ft	8ft	10ft	12ft	14ft
Airfoil Material	6005A Structural Grade Aluminum				
Airfoil Width	7 in				
Number of Airfoils	4				
Airfoil Color	Black Matte				



PERFORMANCE	7ft	8ft	10ft	12ft	14ft
Max Speed (RPM)	200	156	139	108	108
Recommended Spacing	32 ft	32 ft	40 ft	48 ft	56 ft
Max Affected Area (SQFT)	1,225	1,600	2,500	3,600	4,900
Sound Level dBA at Max Speed	<55	<55	<55	<55	<55
Air Volume (cfm)*	42,074	45,787	74,774	91,901	121,923

HANGING REQUIREMENTS	7ft	8ft	10ft	12ft	14ft
Hanging Weight (lbs)	100	104	108	117	121
Max Torque (ft*lb)	12.8	12.8	26	32.5	33.5

* for AMCA 230-15 rating please see: <https://www.amca.org/certified-listed/products.html?c=3422&t=24#large-diameter-ceiling-fan>



XP

MOTOR AND DRIVE TRAIN 7ft 8ft 10ft 12ft 14ft

Motor Type	Brushless Direct Current Motor				
Equivalent Horsepower Rating	5/8 HP				
Operating Temp Range	14° to 140° F (-10° to 60° C)				
Motor Color	Black Matte				

MAX AMP DRAW 7ft 8ft 10ft 12ft 14ft

100-120V Single Phase	5.5 A	4.2 A	7.6 A	7 A	6.2 A
-----------------------	-------	-------	-------	-----	-------

POWER AND CONTROLS

Power Source	AC 1PH 100-120V 50-60HZ
Main Controller	Variable Frequency Drive
Wall Control Options	Digital HMI 350, 500 or 700E Series
Building Management Control Options	BACnet MS/TP, BACnet IP, Modbus RTU

INSTALLATION

Mounting Options	Unistrut
Downrod Length	2 ft, 3 ft, 4 ft
Motor Wiring	Pre-wired motor cables with twist lock connections
HMI Wiring	CAT5/RJ45 Power Over Ethernet (POE)

Hunter
INDUSTRIAL

XP

RATINGS AND COMPLIANCE

Fire and Sprinkler	NFPA 13 and NFPA 72 Compliant
Wash Down Duty Rating	Damp rated
Certifications	ETL/INTERTEK-CERTIFIED TO ANSI/UL 507 AND CSA C22.2 NO.113, IEC 61800-3, CE, AMCA Certified
Safety Features	Redundant Blade Attachment System, Safety Retention Cable, Motor & Drive Protections, Fire Relay
Warranty	Limited Lifetime Warranty



(XP 8FT Fan pictured above)