



Hunter
INDUSTRIAL



TITAN

AIRFOIL DIAMETER	14ft	16ft	18ft	20ft	24ft
Airfoil Material	6005A Structural Grade Aluminum				
Airfoil Width	7 in				
Number of Airfoils	5				
Airfoil Color	Anodized Silver				

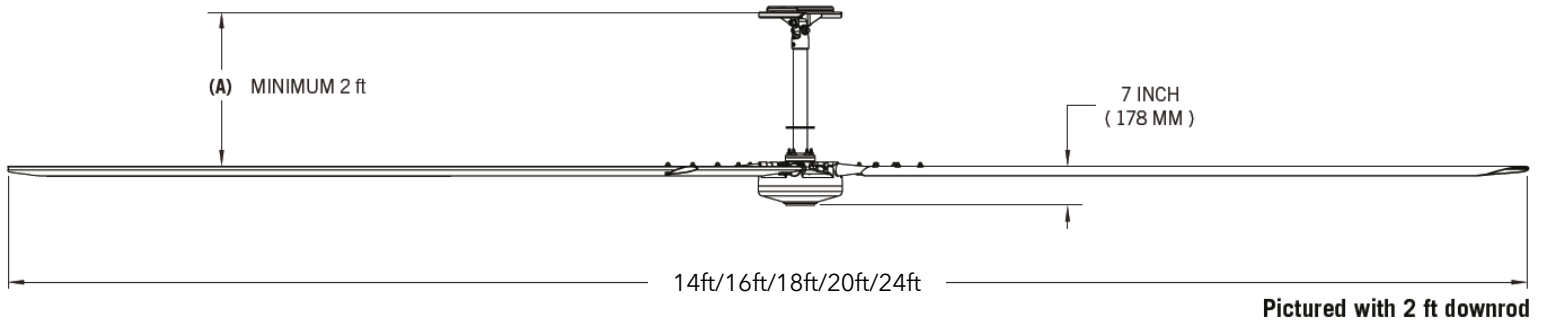

PERFORMANCE	14ft	16ft	18ft	20ft	24ft
Max Speed (RPM)	105	102	95	82	70
Recommended Spacing	70 ft	80 ft	90 ft	100 ft	120 ft
Max Affected Area (SQFT)	7,744	10,000	12,769	15,625	22,500
Sound Level dBA at Max Speed	<55	<55	<55	<55	<55
Air Volume (cfm)*	122,215	183,096	205,449	229,695	316,000

HANGING REQUIREMENTS	14ft	16ft	18ft	20ft	24ft
Hanging Weight (lbs)	168	175	183	190	204
Max Torque (ft*lb)	37 ft	52 ft	58 ft	61 ft	74 ft



TITAN

MOTOR AND DRIVE TRAIN	14ft	16ft	18ft	20ft	24ft
Motor Type	Brushless Direct Current Motor				
Equivalent Horsepower Rating	3/4 HP	1 HP	1 HP	1 HP	1 HP
Operating Temp Range	14° to 140° F (-10° to 60° C)				

* for AMCA 230-15 rating please see: <https://www.amca.org/certified-listed/products.html?c=3422&t=24#large-diameter-ceiling-fan>

MAX AMP DRAW	14ft	16ft	18ft	20ft	24ft
200-240V Single Phase	5.4 A	7.2 A	7.8 A	7.2 A	8.2 A
200-240V Three Phase	2.8A	3.8 A	4.1 A	4.0 A	4.3 A
400-480V Three Phase	1.2A	1.8 A	2.4 A	2.6 A	3.0 A

POWER AND CONTROLS	
Power Source	AC 1PH 200-240V 50-60HZ, AC 3PH 200-240V 50-60HZ, AC 3PH 380-480V 50-60HZ
Main Controller	Variable Frequency Drive
Wall Control Options	Digital HMI 350, 500 or 700E Series
Building Management Control Options	BACnet MS/TP, BACnet IP, Modbus RTU

INSTALLATION	
Mounting Options	I-Beam, Glulam, Unistrut or Perlin
Downrod Length	2ft - 10ft
Extension	Downrods available in 1 ft increments: 2 ft min., 10 ft max. Downrod length must be specified at time of order. Above 10ft inquire.
Motor Wiring	Pre-wired motor cables with twist lock connections
HMI Wiring	CAT5/RJ45 Power Over Ethernet (POE)

Hunter
INDUSTRIAL

TITAN

RATINGS AND COMPLIANCE

Fire and Sprinkler	NFPA 13 and NFPA 72 Compliant
Wash Down Duty Rating	Damp rated
Certifications	ETL/INTERTEK-CERTIFIED TO ANSI/UL 507 AND CSA C22.2 NO.113, IEC 61800-3, CE, AMCA Certified
Safety Features	Redundant Blade Attachment System, Safety Retention Cable, Motor & Drive Protections, Fire Relay
Warranty	Limited Lifetime Warranty



(TITAN 14FT Fan pictured above)